

MCT-425, MCT-425C

Supervised Wireless PowerCode Smoke Detector



Installation Instructions

1. DESCRIPTION AND APPLICATIONS

The MCT-425 and MCT-425C are smoke-automatic fire detectors with integral audible signal for open area protection, designed to sense smoke (not gas, heat or flame) and fitted with a PowerCode type UHF transmitter. MCT-425C is for CANADA only.

The smoke detector provides early warning of developing fire by sounding an alarm with its built-in alarm horn, and by transmitting a coded alarm signal to a PowerCode receiver or to a compatible wireless alarm control panel. For UL approved installation use only PowerMax+ control panel.

It must be borne in mind, though that effective prewarning of fire accidents is only possible if the detector is located, installed and maintained as described here.

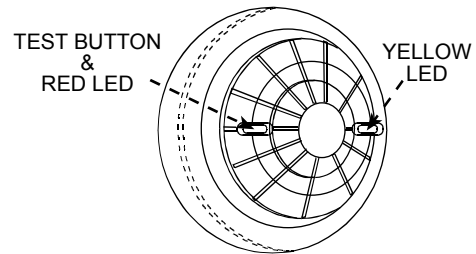

Figure 1. General View

2. SPECIFICATIONS

SMOKE DETECTOR

Alarm Sound Level: 85 dB at 3 m (10 feet)

TRANSMITTER AND CODING

Operating Frequency (MHz): 315, 433.92, 868.95, 869.2625 or other frequency according to local requirements.

Transmitter's ID Code: 24-bit digital word, over 16 million combinations, pulse width modulation.

Overall Message Length: 36 bits

Supervision: Automatic signaling at 60-minute intervals (315 MHz version), 15-minute interval (433.92, 868.95, 869.2625 MHz versions) or according to the local standards.

Tamper Alerts: Tamper event (removal of the unit from its bracket) is reported once. Tamper restore is reported when the tamper switch is restored.

Transmission Indicator: Yellow LED lights upon transmission (visible only when Switch SW-1 is ON).

ALARM REPORT:

Every 20 sec. for the first 3 minutes.

Every 3 min. for the next 27 minutes.

Alarm stops reporting after 30 min., or if the detector goes into "alarm restore".

ELECTRICAL DATA

Power Source: 9 Volt alkaline or lithium.

Operation Voltage: From 7.2 V to 9 V.

Current Drain: 28 μ A standby, 20 mA in operation

Smoke Density:

Europe: 0.15 – 0.2 dB/m

USA & CANADA: 0.61%/ft to 1.27%/ft

Cover Range: 50 cubic meters (1765.5 cubic ft.)

Battery Life Expectancy:

Alkaline: at least 1 year (for typical use) for battery types Eveready (Energizer) #E522, Duracell #MN1604, GP GP1604AU

Lithium: at least 1 year (for typical use) for battery type Ultralife # U9VL-V.

Battery Supervision: Automatic transmission of battery status data as part of any transmitted message.

Audible and Visual Low Battery Warning: Built-in horn beeps every 30 seconds simultaneously with red LED flashing (for up to 30 days when the battery voltage drops).

Audible and Visual Degraded Chamber Sensitivity Warning: Built-in horn beeps every 30 seconds in the middle of red LED flashing intervals – indicate that the sensor should be cleaned.

Clean Warning Transmission: A clean (maintenance) signal is transmitted when the detector's chamber sensitivity becomes degraded.

Note: This transmission applies to the PowerMax+ control panel only

PHYSICAL DATA

Operating Temperature: 0°C to 50°C (32°F to 122°F).

Relative Humidity: 10% to 85%

Dimensions: 130 mm (5.12") x 75 mm (2.95")

Weight (including battery): 272 g (9.6 oz)

Compliance with Standard:

MCT-425 Europe: (868.95, 433.92 and 869.2625 MHz):

CE/RTTE - EN 30220, EN 301489, EN 50130-4. (UK) BS 5446, EN54-7, EN 14604, UK (868.95 MHz).

MCT-425 USA (315MHz): (FCC) CFR47 Part 15, UL 268

MCT-425C CANADA: (IC) RSS210, (ULC) CAN/ULC-S529-02

3. INSTALLATION

3.1 Disassembly

Separate the unit from its mounting bracket as shown in Figure 2.

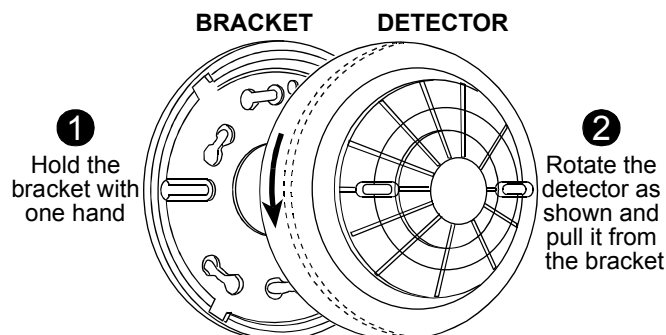

Figure 2. Separating the Detector from Its Bracket

3.2 Setting the Function Switch

The MCT-425 and MCT-425C have a 4-position DIP switch function selector (see Figure 3). The switch levers are numbered 1 to 4, and each switch allows you to select one of two options.

Set the function switches as desired. The ON position is indicated on the switch body.

Table 1. Function switch settings

SW.	Marking	Pos.	Selected Option	Default
SW-1	LED	ON	Yellow LED will light upon transmission	ON
		OFF	Yellow LED is disabled	
SW-2	RST	ON	"Restore" events reported	ON
		OFF	"Restore" events not reported	
SW-3	—	ON	Do not use!	OFF
		OFF	Do not use!	
SW-4	—	ON	Do not use!	OFF
		OFF	Do not use!	

3.3 Definitions of LED Light and Buzzer

The red and yellow LED light and buzzer turn on and/or off to indicate the following conditions:

- A. When the red LED blink once every 30 seconds, this means **power on**, i.e., the detector is energized.
- B. When the red LED flashes and the buzzer beeps intermittently, this means **alarm for potential smoke hazard**.
- C. When the red LED flashes together with buzzer beeps every 30 seconds, this means **battery power is low**.
- D. When the buzzer sounds every 30 seconds, in the middle of red LED flashing interval, it indicates degraded chamber sensitivity (the smoke detector must be cleaned).
- E. The yellow LED turns on each time an RF signal is transmitted to the control panel.

3.4 Battery Connection and Initial Test

Attention: The detector battery cover is fitted with a red button that prevents the detector from locking onto bracket if there is no battery inside.

The smoke detector is supplied with a 9V battery seated within its holder but insulated from the battery terminals.

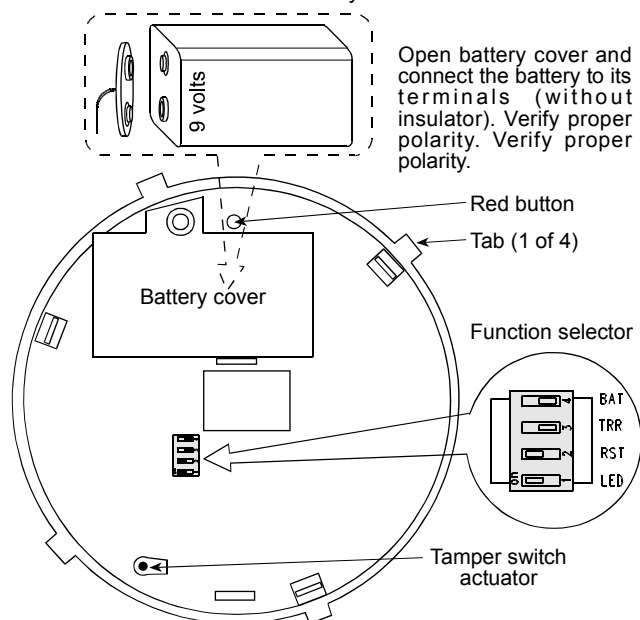

Figure 3. Smoke Detector Rear Side

Note: When the battery first makes contact, the alarm horn may sound for one second. This indicates that the battery is connected properly.

Close the cover, then press the test button (see fig. 1) for about 5 seconds until the horn sounds two sequences of a loud 3-beep alarm. This means that the smoke detection section is working properly.

3.5 Resetting the Transmitter Module and Enrolling its PowerCode ID

A rear tamper protection switch is mounted under the PC board. The tamper switch actuator, extending through a hole in the base (see Figure 3), is pressed against the bracket when the unit is attached to the bracket.

Removal of the unit from the bracket will cause the switch contacts to open, creating a tamper event, which will be reported by the transmitter to the control panel.

Refer to the control panel's installation instructions and follow the procedure given there for enrolling transmitter IDs in the control panel's memory.

When required to initiate a transmission for enrollment, press the smoke detector's test button (see fig. 1) until the built-in horn sounds, or press the tamper switch.

Note: It is much easier to carry out this operation while holding the MCT-425 / MCT-425C in your hand, close to the control panel.

3.6 Mounting

Note: In Canada, detectors are to be installed in accordance with the Standard for Installations of Fire Alarm Systems CAN/ULC-S524-01, in accordance with the Canadian Electrical Code, Part I and in a manner acceptable to the local authority having jurisdiction.

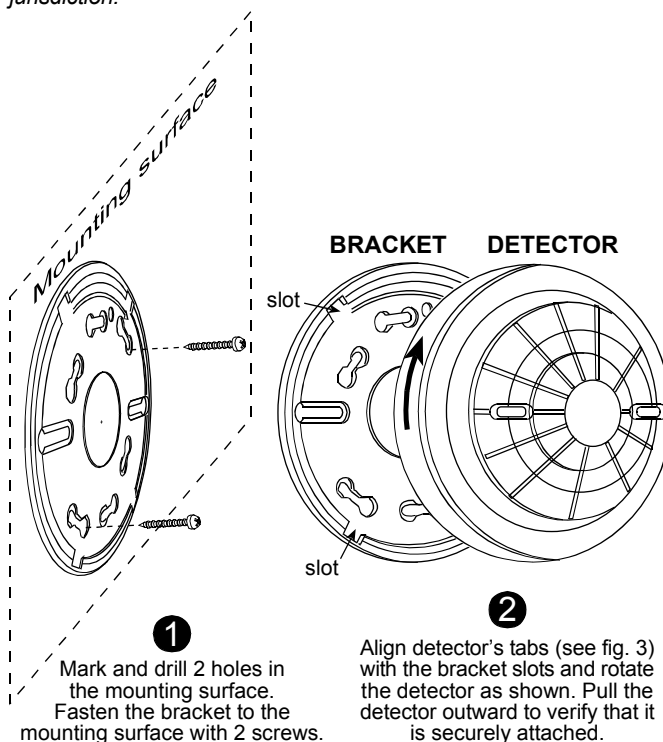

Figure 4. Mounting

Notes

1. A battery must be inserted into the detector before the detector can be mounted onto the bracket.
2. Unauthorized removal of the unit from the bracket will initiate a tamper alert!

3.7 Test

Press the test button (see fig. 1) until the built-in horn sounds. Verify that the transmitted signal has been received at the control panel, and that the control panel responds accordingly by activating the fire alarm siren or any other warning device.

4. SMOKE DETECTOR INSTALLATION OVERVIEW

4.1 Where to Install Smoke Detectors

Smoke detectors should be installed in accordance with the NFPA Standard 72 (National Fire Protection Association, Batterymarch Park, Quincy, MA 02169). For complete coverage in residential units, smoke detectors should be installed in all rooms, halls, storage areas, basements and attics in each family living unit. Minimum coverage is one detector on each floor and one in each sleeping area. For maximum protection, a smoke detector should be located outside primary sleeping areas or on each level of your home. Here are a few useful tips for you:

- Install a smoke detector in the hallway outside every separate bedroom area, as in Figure 5. Two detectors are required in homes with two bedroom areas, as in Figure 6.
- Install a smoke detector on every floor of a multi-floor home or apartment, as shown in Figure 7.
- Install a minimum of two detectors in any household.
- Install a smoke detector inside every bedroom.
- Install smoke detectors at both ends of a bedroom hallway if the hallway is more than 12 meters (40 feet) long.

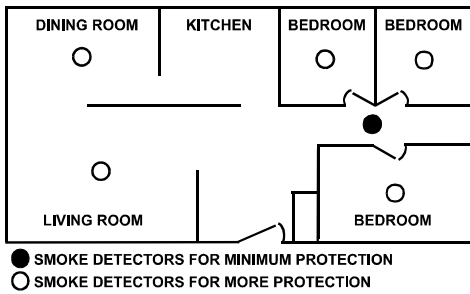

Figure 5. Locations for Placing Smoke Detectors in a Single Residence with only One Sleeping Area

- Install a smoke detector inside every room where one sleeps with the door partly or completely closed, since smoke could be blocked by the closed door and a hallway alarm may not wake up the sleeper if the door is closed.

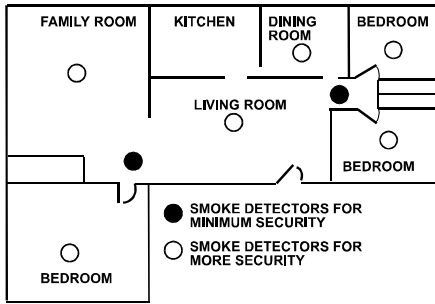

Figure 6. Locations for Placing Smoke Detectors in Single-Floor Residence with More than One Sleeping Area.

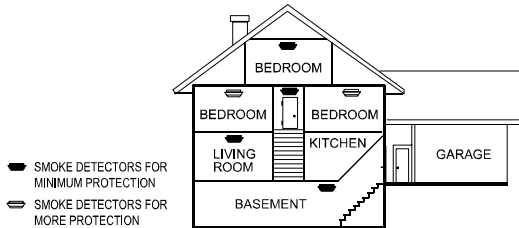

Figure 7. Placing Smoke Detectors in a Multi-Floor Residence

- Install basement detectors at the bottom of the basement stairwell.
- Install second-floor detectors at the top of the first-to-second floor stairwell.
- Be sure no door or other obstruction blocks the path of smoke to the detector.
- Install additional detectors in your living room, dining room, family room, attic, utility and storage rooms.
- Install smoke detectors as close to the center of the ceiling as possible. If this is not practical, put the detector on the ceiling, at least 10 cm (4 inches) away from any wall or corner, as shown in Figure 8.
- If ceiling mounting is not possible and wall mounting is permitted by your local and state codes, locate the detectors between 10 - 15 cm (4 - 6 inches) from the ceiling, also see Figure 8.
- If some of your rooms have sloped, peaked, or gabled ceilings, try to mount detectors 0.9 meter (3 feet) measured horizontally from the highest point of the ceiling as shown in Figure 9.

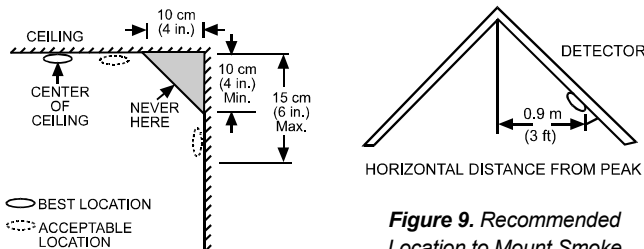

Figure 8. Recommended Best and Acceptable Locations to Mount Smoke Detectors

Figure 9. Recommended Location to Mount Smoke Detectors in Rooms with Sloped, Gabled or Peaked Ceiling



CAUTION (As required by the California State Fire Marshall)

"Early warning fire detection is best achieved by the installation of fire detection equipment in all rooms and areas of the household as follows:

- (1) A smoke detector installed in each separate sleeping area (in the vicinity, but outside the bedrooms), and (2) Heat or smoke detectors in the living rooms, dining rooms, bedrooms, kitchens, hallways, attics, furnace rooms, closets, utility and storage rooms, basements and attached garages."

4.2 Where Not to Install Smoke Detectors

False alarms occur when smoke detectors are installed where they will not work properly. To avoid false alarms, do not install smoke detectors in the following situations:

- Combustion particles are by-products of something burning. Do not install smoke detectors in or near areas where combustion particles are present, such as kitchens with few windows or poor ventilation, garages where there may be vehicle exhaust, near furnaces, hot water heaters and space heaters.
- Do not install smoke detectors less than 6 meters (20 feet) away from places where combustion particles are normally present, like kitchens. If a 20-foot distance is not possible, try to install the detector as far away from the combustion particles as possible, preferably on the wall. To prevent false alarms, provide good ventilation in such places.
- IMPORTANT:** Never try to avoid false alarms by disabling the detector.
- Do not mount smoke detectors in the path of fresh air intake. The flow of fresh air in and out can drive smoke away from the smoke detector; thus reducing its efficiency. Figure 10 indicates the correct and incorrect locations concerning this problem.
- Near pain thinner fumes.
- In close proximity to an automobile exhaust pipe; this will damage the detector.
- In damp or very humid areas or near bathrooms with showers. Moisture in humid air can enter the sensing chamber, then turns into droplets upon cooling, which can cause false alarms. Install smoke detectors at least 3 meters (10 feet) away from bathrooms.
- In very cold or very hot areas, including unheated buildings or outdoor rooms. If the temperature goes above or below the operating range of smoke detector, it will not work properly. The temperature range for your smoke detector is 0°C to 38°C (32°F to 100°F).
- In very dusty or dirty areas, dirt and dust can build up on the detector's sensing chamber, to make it overly sensitive.
- Additionally, dust or dirt can block openings to the sensing chamber and keep the detector from sensing smoke.
- Near fresh air vents or very drafty areas like air conditioners, heaters or fans. Fresh air vents and drafts can drive smoke away from smoke detectors.
- Dead air spaces are often at the top of a peaked roof, or in the corners between ceilings and walls. Dead air may prevent smoke from reaching a detector. See Figures 8 and 9 for recommended mounting locations.
- In insect-infested areas. If insects enter a detector's sensing chamber, they may cause a false alarm. Where bugs are a problem, get rid of them before putting up a detector.
- Near fluorescent lights, electrical "noise" from fluorescent lights may cause false alarms. Install smoke detectors at least 1.5 meters (5 feet) from such lights.
- **Smoke detection depends on the smoke density present in a room. Smoke density is greater in small rooms, for the same amount of smoke, than in large rooms.**

In small rooms less than 25 cubic meters (883 cubic ft.) in size, a small amount of smoke may activate a smoke alert. For example, smoking or bathroom steam may activate a smoke alert.

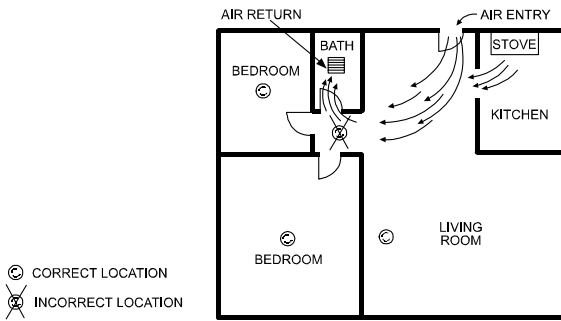

Figure 10. Recommended Smoke Detector Locations to Avoid Air Streams with Combustion Particles

WARNING: Never remove batteries to stop a false alarm. Open a window or fan the air around the detector to get rid of the smoke. The alarm will turn itself off when the smoke is gone. If false alarms persist, attempt to clean the detector as described in this manual.

WARNING: Do not stand close to the detector when the alarm is sounding. The alarm is loud in order to wake you in an emergency. Too much exposure to the horn at close range may be harmful to your hearing.

4.3 Smoke Detector Limitations

- A. This smoke detector is designed for use in a single residential unit or offices, which means that it should be used inside a single family home or apartment or office.
- B. Please refer to NFPA 101, the Life Safety Code, NFPA72 for smoke detector requirements for fire protection in buildings not defined as "households".
- C. **The smoke detector will not sense a fire if the smoke does not reach the sensor.** In order for a smoke detector to sense smoke, it must be installed in the immediate vicinity of the fire. In addition, smoke from fires in chimneys, in walls, on roofs, in remote parts of the building, or on another level from where the smoke detector is located, may not reach the smoke detector quickly enough for occupants to escape unharmed. **For this reason, installer shall install smoke detectors on every level, in every sleeping area and in every bedroom of the household.**

D. Smoke detector may not be heard. The alarm horn in this

smoke detector meets or exceeds current Underwriter's Laboratories standards. However, if the smoke detector is not located in the same room as the occupant or if it is blocked by a closed door or normal noise, the alarm horn may not be heard. In addition, sound sleepers, or persons who are under the influence of drugs or alcohol may not hear the alarm or be able to react to it. **Therefore, locate this smoke detector, which has a sounder rated at 85 dB at 10 feet, on every level, in every sleeping area and in every bedroom of the household.**

- E. This detector, if used as a stand-alone unit, will not alert people who are hard of hearing.
- F. In general, detectors may not always warn you about fires caused by carelessness and safety hazards like smoking in bed, violent explosions, escaping gas, improper storage of flammable materials, overloaded electrical circuits, children playing with matches or arson.
- G. Smoke detectors are not fool-proof. Like all electronic devices, smoke detectors have limitations. No type of smoke detector can sense every kind of fire every time. In addition, smoke from slow, smoldering fires rises slowly and may not reach the smoke detector until actual flame breaks out. This type of smoke may not reach the smoke detector in time for occupants to escaped unharmed.
- H. Smoke detectors are not a substitute for life or property insurance. Though smoke detectors have been responsible for saving many lives, they are not warranted or implied to protect lives or property in the event of fire.
- I. These wireless systems are very reliable and are tested to high standards. However, due to their low transmitting power and limited range (required by the regulatory authorities), there are some limitations to be considered:
 - i) Receivers may be blocked by radio signals on or near their operating frequencies, regardless of the code selected.
 - ii) A receiver can only respond to one transmitted signal at a time.
 - iii) Wireless equipment should be tested regularly to determine whether there are sources of interference and to protect against faults.

5. TAKING CARE OF THE MCT-425 or MCT-425C

5.1 Battery Replacement

The MCT-425 and MCT-425C were designed to be as maintenance-free as possible. To keep the smoke detector in good working order, you must test it weekly, as instructed in Para. 6.1 below.

Make it a rule to replace the detector's battery (alkaline) once a year even if there is no indication that the battery is weak. Also be sure to replace it immediately upon reception of a low battery message via your control panel.

If you disregard this message, an audible reminder in the form of once-per-minute "beep" will sound after a few days. The low-battery "beep" should last at least 30 days before the battery dies out completely.

NOTE: For best performance, use only alkaline or lithium batteries as replacement batteries (see specifications). Carbon zinc batteries are not acceptable. Alkaline batteries can be purchased at any retail store that sells batteries.

Replace the battery as follows:

- A. Separate the detector from its bracket (see figure 2).
- B. Replace battery (see figure 3).

5.2 Maintenance

It is necessary to maintain the detector frequently to ensure it working properly. Follow these tips for taking care of your detector:

- Use a vacuum cleaner to clean the air vents occasionally to keep them free of dust. To clean the detector, remove it from the bracket. Also, perform cleaning when the buzzer sounds every 30 seconds in the middle of LED flashing interval – this indicates degraded chamber sensitivity.
- Perform detector functional test (see par. 3.7) weekly.
- A clean (maintenance) signal is transmitted when the detector's chamber sensitivity becomes degraded.

NOTE: This transmission applies to the PowerMax+ control panel only.

NOTE: If false alarms keep occurring, check whether the detector's location is adequate (see Para. 4.1 and 4.2). Relocate the unit if it is not located properly. Clean as described above.

6. ADDITIONAL ADVICE

6.1 Routine Testing

The detector should be tested weekly and also whenever you suspect that it does not go into alarm. Push the test button firmly with your finger until the horn sounds (it may take up to 20 seconds). Also verify that the control panel responds to the transmitted fire alarm. If the detector fails, have it repaired or

replaced immediately, to ensure that it works properly.

Every 3 months the smoke detector must be checked by using smoke detectors test sprayer.

WARNING: Never use an open flame of any kind to test your detector. You may set fire to damage the detector as well as your home. The built-in test switch accurately tests all

detector functions, as required by Underwriters' Laboratories. This is the only correct way to test the unit.

NOTE: If the alarm horn produces a loud continuous sound and the red LED flashes when you are not testing the unit, this means the detector has sensed smoke or combustion particles in the air. Verify that the alarm is a result of a possible serious situation, which requires your immediate attention.

- The alarm could be caused by a false situation. Cooking smoke or a dusty furnace, sometimes called "friendly fires" can cause the alarm to sound. If this happens, open a window or fan the air away to remove the smoke or dust. The alarm will turn off as soon as the air is completely clear.

CAUTION: Do not disconnect the battery from the detector. This will remove your protection from fires.

- If there is any question as to the cause of an alarm, it should be assumed that the alarm is due to an actual fire and the residence should be evacuated immediately.
- If the alarm horn begins to beep once every 30 sec, this signal means that the detector's battery is weak. Install a new battery immediately. Keep fresh batteries on hand for this purpose.

6.2 Tips to Enhance Your Protection From Fires

Putting up smoke detectors is only one step in protecting your family from fires. You must also reduce the chances of fires starting in your home. You must also increase your chances of escaping safely if one does start. To have a good fire safety program you must apply the following tips to enhance your family's protection from fires:

- A. Install smoke detectors properly. Carefully follow all the instructions in this manual. Keep your smoke detectors clean and test them every week.
- B. Remember that detectors that do not work will not alert you. Replace your smoke detectors immediately if they are not working properly.
- C. Follow fire **safety** rules, and prevent hazardous situations:
 - Use smoking materials properly. Never smoke in bed.
 - Keep matches and cigarette lighters away from children.
 - Store flammable materials in proper containers. Never use them near open flame or sparks.
 - Keep electrical appliances in good condition. Do not overload electrical circuits.
 - Keep stoves, fireplaces, chimneys, and barbecue grills grease free. Make sure they are properly installed and away from any combustible materials.
 - Keep portable heaters and open flames such as candles away from combustible materials.
 - Do not allow rubbish to accumulate.

- Keep a supply of extra batteries on hand for your battery powered smoke detectors.

D. Develop a family escape plan and practice it with your entire family. Be sure to include small children in your practice.

- Draw a floor plan of your home, and find two ways to exit from each room. There should be one way to get out of each bedroom without opening the door.
- Explain to children what the smoke detector alarm signal means. Teach them that they must be prepared to leave the home by themselves if necessary. Show them how to check to see if doors are hot before opening them. Show them how to stay close to the floor and crawl if necessary. Show them how to use the alternate exit if the door is hot and should not be opened.
- Decide on a meeting place which has a safe distance from your house. Make sure that all your children understand that they should go and wait for you there if there is a fire.
- Hold fire drills at least every 6 months, making sure that everyone, even small children, knows what to do to escape safely.
- Know where to go to call the Fire Department outside your home.
- Provide emergency equipment, such as fire extinguishers, and teach your family to use this equipment properly.

6.3 More Tips on How to Face a Fire at Home

If you have made an escape plan and practiced it with your family, their chances of escaping safely are increased. Go over the following rules with your children when you have fire drills. This will help everyone remember the rules in a real emergency.

- A. Don't panic and stay calm. Your safe escape may depend on thinking clearly and remembering what you have practiced.
- B. Get out of the house as quickly as possible. Follow a planned escape route. Do not stop to collect anything or to get dressed.
- C. Feel the doors to see if they are hot. If they are not, open them carefully. Do not open a door if it is hot. Use an alternate escape route.
- D. Stay close to the floor. Smoke and hot gases rise.
- E. Cover your nose and mouth with a wet or damp cloth. Take short, shallow breaths.
- F. Keep doors and windows closed. Open them only if you have to in order to escape.
- G. Meet at your planned meeting place after leaving the house.
- H. Call the Fire Department as soon as possible from outside your house. Give the address and your name.
- I. Never go back inside a burning building. Contact your local Fire Department. They will give you more ideas about how to make your home safer from fires and how to plan your family's escape.

7. STATEMENTS OF COMPLIANCE

The 315 MHz version of this device complies with Part 15 of the FCC Rules. Operation is subject to the following two conditions: (1) This device may not cause harmful interference, and (2) This device must accept any interference received, including interference that may cause undesired operation.

WARNING! Changes or modifications to this unit not expressly approved by the party responsible for compliance could void the user's authority to operate the equipment

The digital circuit of this device has been tested and found to comply with the limits for a Class B digital device, pursuant to Part 15 of the FCC Rules. These limits are designed to provide reasonable protection against harmful interference in residential installations. This equipment generates, uses and can radiate radio frequency energy and, if not installed and used in accordance with the instructions, may cause harmful interference to radio and television reception. However, there is no guarantee that interference will not occur in a particular installation. If this device does cause such interference, which can be verified by turning the device off and on, the user is encouraged to eliminate the interference by one or more of the following measures:

- Re-orient or re-locate the receiving antenna.

- Increase the distance between the device and the receiver.
- Connect the device to an outlet on a circuit different from the one which supplies power to the receiver.
- Consult the dealer or an experienced radio/TV technician.

This device complies with the essential requirements and provisions of Directive 1999/5/EC of the European Parliament and of the Council of 9 March 1999 on radio and telecommunications terminal equipment.

Frequency Allocations for Wireless Devices in European (EU) Countries

- 433.92 MHz has no restriction in any EU member state.
- 315 MHz is not allowed in any EU member state
- 868.95 MHz (wide band) is allowed in all EU member states.
- 869.2625 MHz (narrow band) is not restricted in any EU member state.

WARRANTY

Visonic Limited (the "Manufacturer") warrants this product only (the "Product") to the original purchaser only (the "Purchaser") against defective workmanship and materials under normal use of the Product for a period of twelve (12) months from the date of shipment by the Manufacturer.

This Warranty is absolutely conditional upon the Product having been properly installed, maintained and operated under conditions of normal use in accordance with the Manufacturers recommended installation and operation instructions. Products which have become defective for any other reason, according to the Manufacturers discretion, such as improper installation, failure to follow recommended installation and operational instructions, neglect, willful damage, misuse or vandalism, accidental damage, alteration or tampering, or repair by anyone other than the manufacturer, are not covered by this Warranty.

The Manufacturer does not represent that this Product may not be compromised and/or circumvented or that the Product will prevent any death and/or personal injury and/or damage to property resulting from burglary, robbery, fire or otherwise, or that the Product will in all cases provide adequate warning or protection. The Product, properly installed and maintained, only reduces the risk of such events without warning and it is not a guarantee or insurance that such events will not occur.

THIS WARRANTY IS EXCLUSIVE AND EXPRESSLY IN LIEU OF ALL OTHER WARRANTIES, OBLIGATIONS OR LIABILITIES, WHETHER WRITTEN, ORAL, EXPRESS OR IMPLIED, INCLUDING ANY WARRANTY OF MERCHANTABILITY OR FITNESS FOR A PARTICULAR PURPOSE, OR OTHERWISE. IN NO CASE SHALL THE MANUFACTURER BE LIABLE TO ANYONE FOR ANY CONSEQUENTIAL OR INCIDENTAL DAMAGES FOR BREACH OF THIS WARRANTY OR ANY OTHER WARRANTIES WHATSOEVER, AS AFORESAID.

THE MANUFACTURER SHALL IN NO EVENT BE LIABLE FOR ANY SPECIAL, INDIRECT, INCIDENTAL, CONSEQUENTIAL OR PUNITIVE DAMAGES OR FOR LOSS, DAMAGE, OR EXPENSE, INCLUDING LOSS OF USE, PROFITS, REVENUE, OR GOODWILL, DIRECTLY OR INDIRECTLY ARISING FROM PURCHASER'S USE OR INABILITY TO USE THE PRODUCT, OR FOR LOSS OR DESTRUCTION OF OTHER PROPERTY OR FROM ANY OTHER CAUSE, EVEN IF MANUFACTURER HAS BEEN ADVISED OF THE POSSIBILITY OF SUCH DAMAGE.

THE MANUFACTURER SHALL HAVE NO LIABILITY FOR ANY DEATH, PERSONAL AND/OR BODILY INJURY AND/OR DAMAGE TO PROPERTY OR OTHER LOSS WHETHER DIRECT, INDIRECT, INCIDENTAL, CONSEQUENTIAL OR OTHERWISE, BASED ON A CLAIM THAT THE PRODUCT FAILED TO FUNCTION.

However, if the Manufacturer is held liable, whether directly or indirectly, for any loss or damage arising under this limited warranty, **THE MANUFACTURER'S MAXIMUM LIABILITY (IF ANY) SHALL NOT IN ANY CASE EXCEED THE PURCHASE PRICE OF THE PRODUCT**, which shall be fixed as liquidated damages and not as a penalty, and shall be the complete and exclusive remedy against the Manufacturer.

When accepting the delivery of the Product, the Purchaser agrees to the said conditions of sale and warranty and he recognizes having been informed of.

Some jurisdictions do not allow the exclusion or limitation of incidental or consequential damages, so these limitations may not apply under certain circumstances.

The Manufacturer shall be under no liability whatsoever arising out of the corruption and/or malfunctioning of any telecommunication or electronic equipment or any programs.

The Manufacturers obligations under this Warranty are limited solely to repair and/or replace at the Manufacturer's discretion any Product or part thereof that may prove defective. Any repair and/or replacement shall not extend the original Warranty period. The Manufacturer shall not be responsible for dismantling and/or reinstallation costs. To exercise this Warranty the Product must be returned to the Manufacturer freight pre-paid and insured. All freight and insurance costs are the responsibility of the Purchaser and are not included in this Warranty.

This warranty shall not be modified, varied or extended, and the Manufacturer does not authorize any person to act on its behalf in the modification, variation or extension of this warranty. This warranty shall apply to the Product only. All products, accessories or attachments of others used in conjunction with the Product, including batteries, shall be covered solely by their own warranty, if any. The Manufacturer shall not be liable for any damage or loss whatsoever, whether directly, indirectly, incidentally, consequentially or otherwise, caused by the malfunction of the Product due to products, accessories, or attachments of others, including batteries, used in conjunction with the Products. This Warranty is exclusive to the original Purchaser and is not assignable.

This Warranty is in addition to and does not affect your legal rights. Any provision in this warranty which is contrary to the Law in the state or country where the Product is supplied shall not apply.

Warning: The user must follow the Manufacturer's installation and operational instructions including testing the Product and its whole system at least once a week and to take all necessary precautions for his/her safety and the protection of his/her property.

1/08



W.E.E.E. Product Recycling Declaration

For information regarding the recycling of this product you must contact the company from which you originally purchased it. If you are discarding this product and not returning it for repair then you must ensure that it is returned as identified by your supplier. This product is not to be thrown away with everyday waste.
Directive 2002/96/EC Waste Electrical and Electronic Equipment.



Product Certificate Number 512c/01



VISONIC LTD. (ISRAEL): P.O.B 22020 TEL-AVIV 61220 ISRAEL. PHONE: (972-3) 645-6789, FAX: (972-3) 645-6788
VISONIC INC. (U.S.A.): 65 WEST DUDLEY TOWN ROAD, BLOOMFIELD CT. 06002-1376. PHONE: (860) 243-0833, (800) 223-0020 FAX: (860) 242-8094
VISONIC LTD. (UK): 7 COPPERHOUSE COURT, CALDECOTTE, MILTON KEYNES. MK7 8NL. PHONE: (0870) 7300800 FAX: (0870) 7300801
INTERNET: www.visonic.com

©VISONIC LTD. 2008 MCT-425, MCT-425C D-301296 (old DE3642-) Rev. 2, 05/08)

